

MIDMARK®

Installation and Operation Manual

411 (75L) Power Examination Table

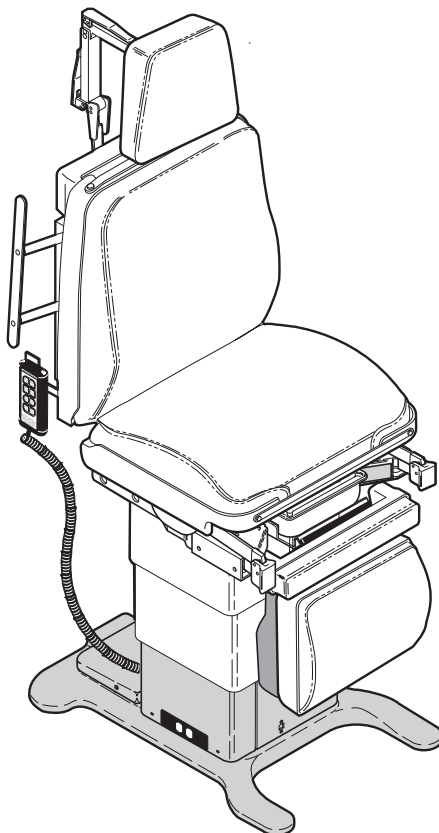

Safety

Page 2

Installation

Page 3

Description

Page 8

**Components
Overview**

Page 9

**Controls &
Indicators**

Page 10

Operation

Page 12

**Operator
Maintenance**

Page 24

**Calling For
Service**

Page 27

Specifications

Page 28

**Limited
Warranty**

Page 29

Owner's Product Identification

(information that you will need to provide for servicing - key information is highlighted)

Date of Purchase

Serial Number

Name of Owner / Facility / Department

Model Number

Name of Authorized Midmark Dealer

Telephone # of Authorized Midmark Dealer

Address of Authorized Midmark Dealer

MODEL AND SERIAL NUMBER LOCATION

MODEL NUMBER

SERIAL NUMBER

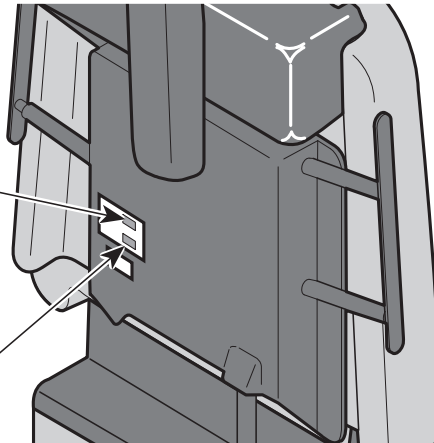

MA347400

CONTENTS

SCOPE AND PURPOSE OF THIS MANUAL	2
SAFETY INSTRUCTIONS	2
Explanation of Safety Symbols and Notes.....	2
INSTALLATION	3
Unpacking.....	3
Leveling The Table.....	4
Installing Hand Control and Foot Control (Optional).....	5
Installing Upholstery	6
Electrical Requirements.....	7
Headrest Adjustment Tools.....	7
DESCRIPTION	8
Introduction.....	8
Features.....	8
COMPONENTS OVERVIEW	9
CONTROLS AND INDICATORS	10
OPERATION	12
Power Features.....	13
Hand Control.....	13
Foot Control (Optional)	14
Back Section Positioning	15
Tilt Function Positioning (Table Top Angle).....	16
Table Function Positioning (Table Height).....	17
Foot Section Positioning	18
Multiple Function Positioning	19
Procto Knee Rest Positioning	19
Stirrups	20
Irrigation Pan	21
Paper Roll	21
Headrest Removal / Installation	22
Headrest Positioning.....	22
Accessory Rails	23
List of Authorized Accessories.....	23
OPERATOR MAINTENANCE	24
Preventive Maintenance	24
Headlock Assembly Adjustment	24
Headlock Handle Stops Adjustment	26
Care Of Table.....	27
CALLING FOR SERVICE	27
SPECIFICATIONS	28
LIMITED WARRANTY	29

SCOPE AND PURPOSE OF THIS MANUAL

This manual covers complete instructions for the installation, operation, and normal care of the Model 411(75L) Power Examination Table. It is intended that this manual be used by any medical personnel responsible for operating the examination table during a medical procedure or performing operator level maintenance.

SAFETY INSTRUCTIONS

The primary concern of Midmark is that this equipment is operated and maintained with the safety of the patient and staff in mind. To assure safer and more reliable operation:

- Read and understand this manual before attempting to install or operate the table.
- Assure that appropriate personnel are informed on the contents of this manual; this is the responsibility of the purchaser.
- Assure that this manual is located near the table, or if possible, permanently affixed to the table.

Explanation of Safety Symbols and Notes



DANGER

Indicates an imminently hazardous situation which, if not avoided, will result in death or serious injury. The **DANGER** symbol is limited to the most extreme situations.



WARNING

Indicates a potentially hazardous situation which, if not avoided, could result in death or serious injury.



CAUTION

Indicates a potentially hazardous situation which, if not avoided, may result in minor or moderate injury. It may also be used to alert against unsafe practices.

**EQUIPMENT ALERT**

Indicates an imminently or potentially hazardous situation which, if not avoided, will or may result in serious, moderate, or minor equipment damage.

NOTE

Amplifies an operating procedure, practice, or condition.

INSTALLATION

Unpacking

**EQUIPMENT ALERT**

To avoid damaging the table's upholstered top or side panels, do not use a knife or other sharp object to open the table's packaging. Also, to avoid damaging the table, do not lift at points (1, Figure 2).

Carefully remove the packaging from the table and upholstery. Then inspect the table and upholstery for any shipping damage. Report any damage to the shipping company and fill out a concealed damage report.

Using a 1/2 in. open end wrench or socket, unbolt the table from the wooden shipping skid by removing four bolts (2, Figure 2) from the underside of the table's base; one at each corner.

**WARNING**

The table weighs approximately 550 lb. (249.5 kg). Get an assistant(s) to help remove the table from the shipping skid. Also, use proper lifting techniques when lifting table. Failure to do so could result in serious back injury.

After unbolting, remove the table from the shipping skid (3), lifting at points (4 and 5). **Do not** lift at points (1); these are unsupported areas. Position the table in room as desired.

Remove packing tape from stirrups. Pull out irrigation pan slide (6) and remove packing tape from the drain pan assembly components. Remove the Installation & Operation Manual and hand control from drain pan (7). Return irrigation pan slide (6) to its stowed position.

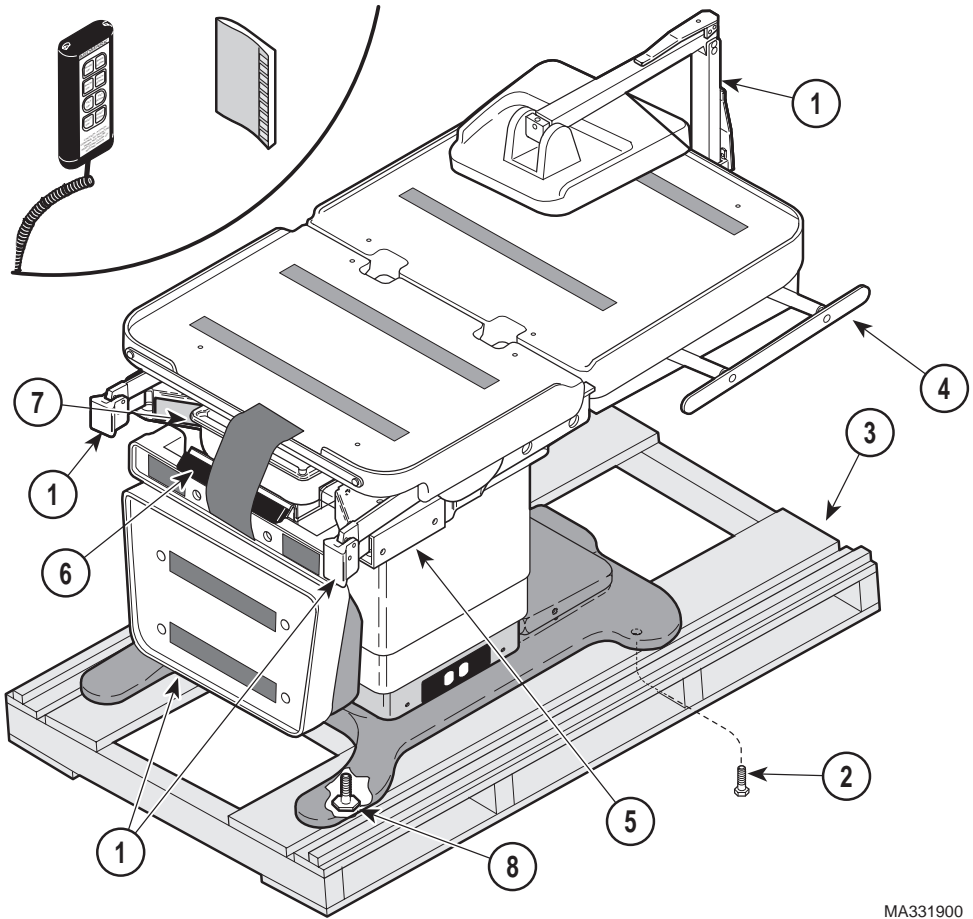

MA331900

Figure 2. Table Installation

Leveling The Table

A leveling screw pad (8, Figure 2) is located under each corner of the table's base. Adjust the four leveling screw pads (8) up or down (by turning them) until a solid, level installation is achieved.

Installing Hand Control and Foot Control (Optional)

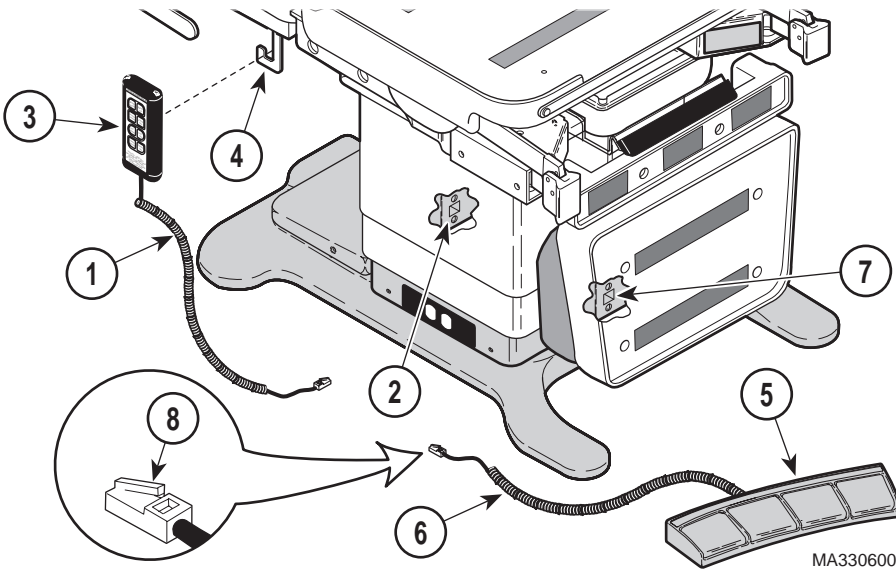

NOTE

If desired, the hand control hanger (4) may be moved to the opposite side of the table by removing the two bolts and nuts securing it and then remounting it using the two predrilled holes on the opposite side of the table. If it is desired to have a hand control hanger on both sides of the table, an extra hand control hanger may be purchased.

To install the hand control, remove the hand control and hand control coil cord from its shipping location in the drain pan assembly (7, Figure 2). Insert the end of coil cord (1) into hand control port (2). Hang the hand control (3) in the hand control hanger (4).

To install the foot control (optional accessory), remove the foot control (5) from its shipping box. Insert end of the coil cord (6) into foot control receptacle (7).

To disconnect a coil cord of hand control or foot control from table, depress the tab (8) on coil cord plug. If desired, the hand control and foot control plug-in locations may be interchanged; the hand control may be plugged into foot control receptacle (7) and the foot control may be plugged into hand control receptacle (2).

Installing Upholstery

Installation

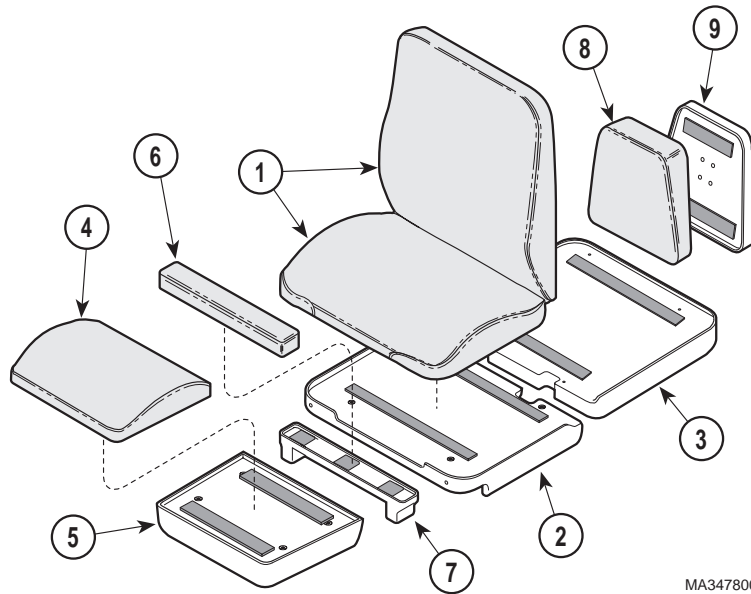

EQUIPMENT ALERT

Do not use a knife or other sharp object to open the packaging. Failure to do so could result in damage to upholstery.

The upholstery for the table is supplied in a separate box. Remove the upholstery from the packaging and inspect it for damage. Operate the table so that the FOOT section is horizontal, the TILT function is level, and the BACK section is approximately 10° above horizontal (*See Operation in this manual for instructions*).

To install the seat and back upholstery, install the shorter end of the seat and back upholstery (1) onto the seat board (2), while making sure the front corners of the upholstery are in alignment with the seat board. Then, press the upholstery firmly against the velcro of the seat board. Next, pull up lightly on the back portion of the seat and back upholstery (1) to fully extend the vinyl over the gap between the seat and back boards. Align the upper corners of the back upholstery with the back board (3). Then, press the upholstery firmly against the velcro of the back board.

To install the foot rest upholstery, align the foot rest upholstery (4) with the foot board (5) and then press foot rest upholstery firmly against velcro of foot board.

To install the leg rest upholstery, align the leg rest upholstery (6) with the leg board (7) and then press leg rest upholstery firmly against velcro of leg board.

To install the head rest upholstery, align the head rest upholstery (8) with the head board (9) and then press head rest upholstery firmly against velcro of head board.

Electrical Requirements



WARNING

Most exposed metal parts of the table are electrically grounded. When performing a cauterization or similar treatment, the patient must be insulated from the metal portions of the table by nonconductive material. Failure to do so could result in electrical shock or burns to the patient.

Use 115 VAC, 60 HZ alternating current only. Failure to do so could result in electrical shock to personnel and will result in damage to table.

Do not use this table in an explosive or oxygen-enriched atmosphere. Failure to do so could result in serious personal injury or death.

NOTE

Grounding reliability can only be achieved if this equipment is connected to an equivalent receptacle marked Hospital Grade (NEMA 5-15R, HOSPITAL GRADE).

The electrical rating for the Model 411(75L) Power Examination table is 115 VAC, 60 Hz, 12 amps. The three-pronged grounding plug on the table power cord must be plugged into a matching three-pronged, grounded, non-isolated, correctly polarized 115 VAC receptacle. The table power cord provides power for all electrical functions of the table, including the duplex receptacles.

Headrest Adjustment Tools

The wrenches necessary to adjust the headlock assembly have been provided. These wrenches are in a bag which has been attached to the headlock assembly of the table. Remove this bag of wrenches before using the table and store these tools with the Installation & Operation Manual.

DESCRIPTION

Introduction

The 75L Power Examination Table is primarily used in examination rooms for general examinations and minor procedures. The combinations of its four powered motions, adjustable procto knee rest, stirrups, irrigation pan, and adjustable headrest provide a table which can be tailored to facilitate most examinations and treatments being performed in a doctor's office. The 411(75L) is designed to reduce the effort and fatigue, and increase safety involved in the examination and treatment of patients.

Features

The Model 411 (75L) Powered Examination Table has . . .

- powered positioning of its four functions; back up and down, tilt up and down, foot up and down, and table up and down.
- a manually adjustable head rest which may be adjusted to allow the operator to position the patient's head in specific position or orientation.
- a manually adjustable leg rest which may be adjusted into a procto knee rest position for proctologic examinations.
- right and left stirrups which can be extended to an infinite number of positions as well as laterally in three positions.
- accessory rails to allow use of mounted accessories with table.
- two duplex, hospital grade 115 VAC receptacles, one located on each side of the table to power accessories or instruments.
- a paper roll holder which is hidden in the head end of the upholstered top, and tear strips, located at the foot end and head end of the upholstered top, to secure examination paper during a patient examination or procedure.

COMPONENTS OVERVIEW

The illustration below shows the location of the table's major components and the chart below provides their descriptive name.

DESCRIPTION OF COMPONENTS

1. Back Section (adjustable angle)	7. Hand Control
2. Seat Section (adjustable tilt)	8. Foot Control (optional)
3. Foot Section (adjustable angle)	9. Duplex Receptacle
4. Headrest (adjustable)	10. Accessory Rails
5. Headlock Assembly	11. Treatment Irrigation Pan
6. Stirrups	12. Paper Roll Holder

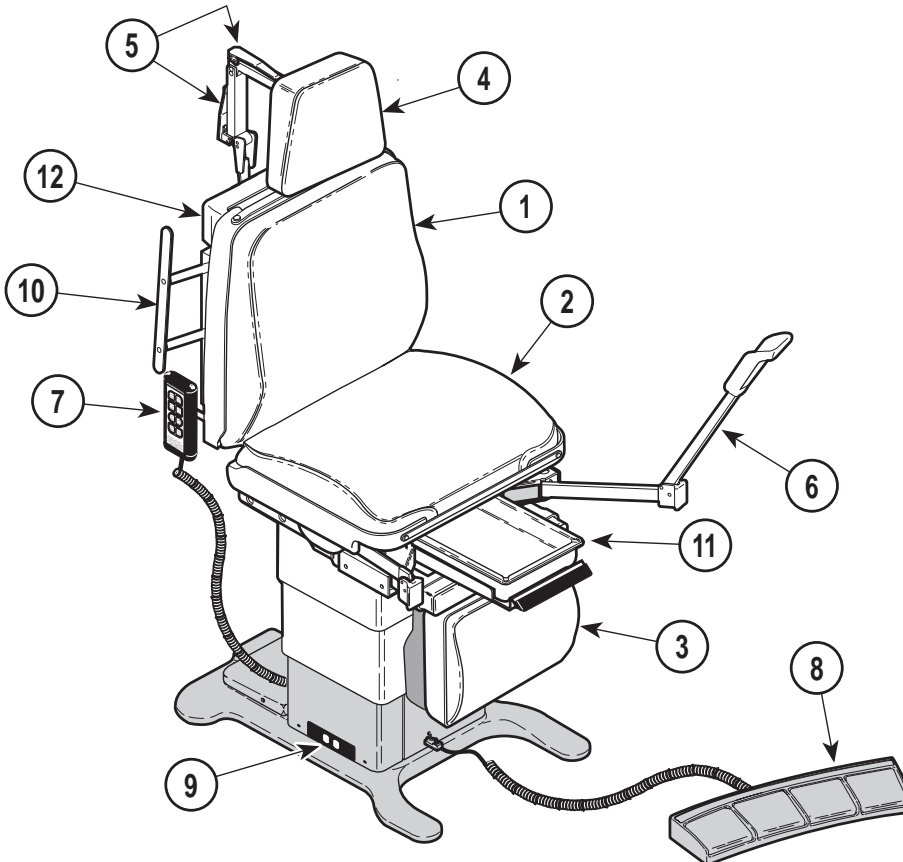

Description

Components Overview

CONTROLS & INDICATORS

The following illustrations show the location of the table's controls and indicators and the chart below describes their function.

Ref.	Control / Indicator	Function
1	<i>Base Up / Table Up button</i>	<i>when pressed, the entire table top is raised.</i>
2	<i>Base Down / Table Down button</i>	<i>when pressed, the entire table top is lowered.</i>
3	<i>Back Up button</i>	<i>when pressed, the back section raises.</i>
4	<i>Back Down button</i>	<i>when pressed, the back section lowers.</i>
5	<i>Tilt Up button</i>	<i>when pressed, the front of seat section raises upward, tilting the entire table top.</i>
6	<i>Tilt Down button</i>	<i>when pressed, the front of seat section lowers downward, tilting the entire table top.</i>
7	<i>Foot Up button</i>	<i>when pressed, the foot section raises.</i>
8	<i>Foot Down button</i>	<i>when pressed, the foot section lowers.</i>
9	<i>Foot Rest Release handles</i>	<i>used to release foot rest so it may be removed from table.</i>
10	<i>Head Lock handles</i>	<i>used to unlock the headlock assembly so it may be positioned and then relocked in the desired position.</i>
11	<i>Headrest Releases</i>	<i>Three quick releases are used to quickly remove headrest from headlock assembly so it may be replaced with different type headrest.</i>
12	<i>Duplex receptacle</i>	<i>provides power to small accessories used during an examination or procedure.</i>

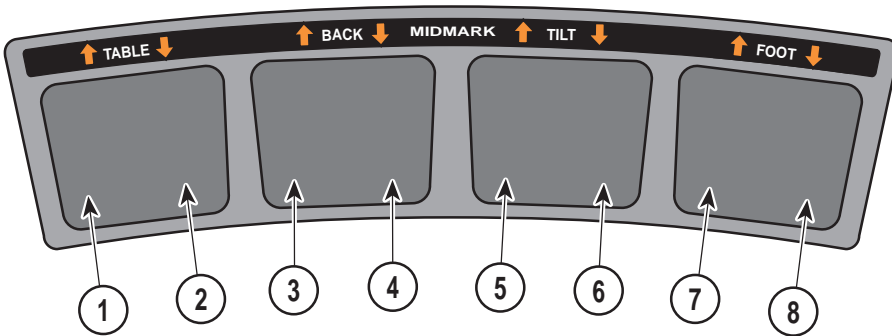
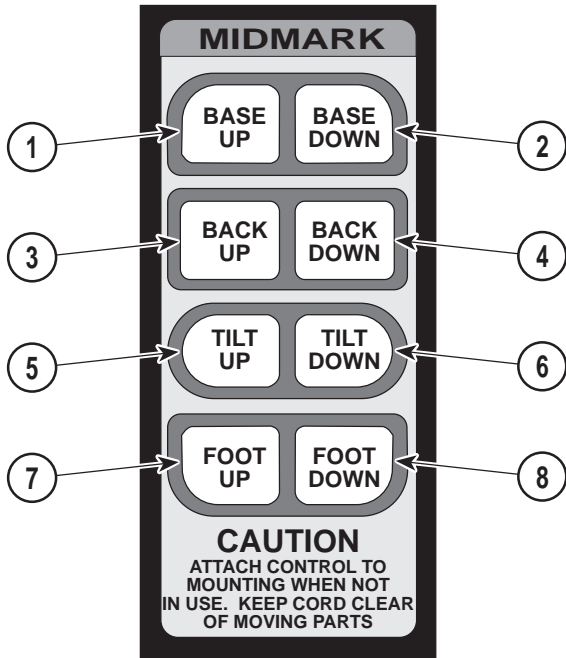

MA331100

Controls & Indicators

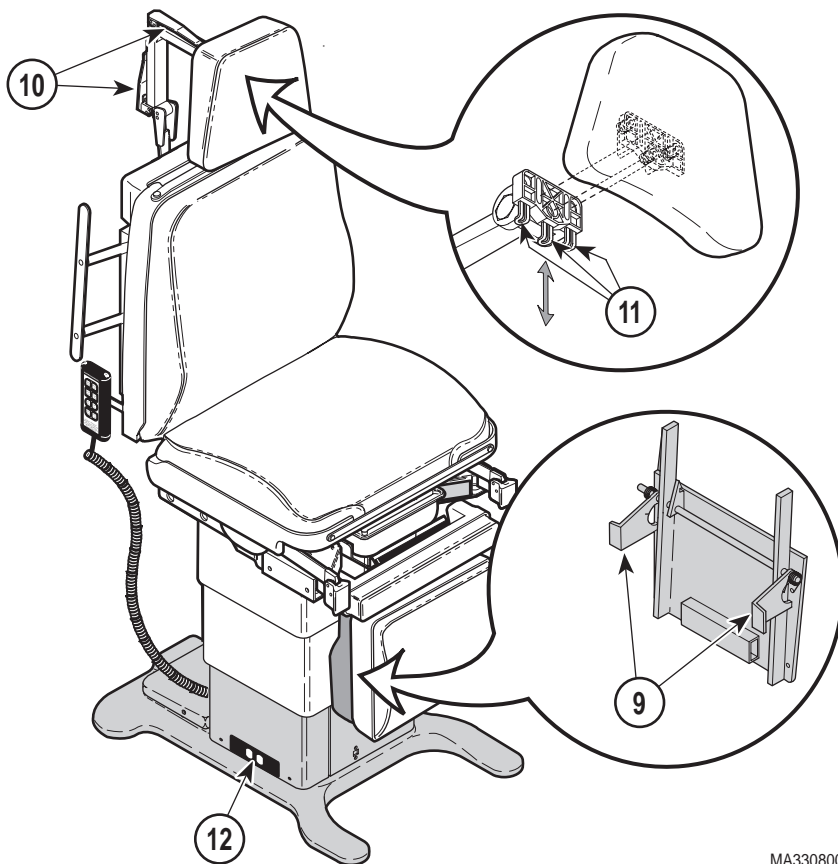

MA330800

OPERATION



WARNING

Do not use this table in an explosive or oxygen-rich atmosphere. To do so could result in an explosion or fire.

If the table malfunctions, immediately remove your hand or foot from button / footswitch rocker, unplug the power cord from the receptacle, and assist the patient from the table.

Keep personnel and equipment clear of table before initiating power movement to avoid personal injury or equipment damage.



EQUIPMENT ALERT

For optimal table performance, allow the table to reach room temperature before operating.

NOTE

This equipment is not designed for continuous operation; each motor has a thermal overload safety switch to protect it from overheating. If the unit is operated continually, causing one of the motors to overheat, the thermal overload safety switch for that function will shut off the overheated motor. If normal operation of a function ceases, immediately stop attempting to operate the table and allow function to cool for 10 to 15 minutes before using again. The thermal overload safety switch will automatically reset when the motor cools to a safe temperature.

Power Features

Each motor (back actuator, tilt actuator, table actuator, and foot actuator) has a thermal overload safety switch to prevent the motor from overheating and being damaged. Each motor is also protected by a fuse to prevent excessive current draw which could damage the motor. If operation of a function does not return after a cooling period of one hour, contact your dealer or an authorized service center for repair (See Calling For Service in this manual).

The 411(75L) table's four powered table functions are controlled by either the hand control or foot control (optional).

Hand Control



EQUIPMENT ALERT

The hand control is moisture resistant and runs on low voltage, eliminating hand control shock hazards. However, to avoid temporary or permanent damage to the hand control, avoid immersing the hand control in water / fluids.

To use the hand control (1), remove the hand control from its hanger (2) and hold it in the palm of your hand, or if desired, let the hand control remain mounted on the hanger. Depress the button of the desired function to activate that function. If removed, replace the hand control (1) on its hanger (2) when table positioning is completed. A more detailed description of each of the hand control functions is included throughout the remainder of this section.

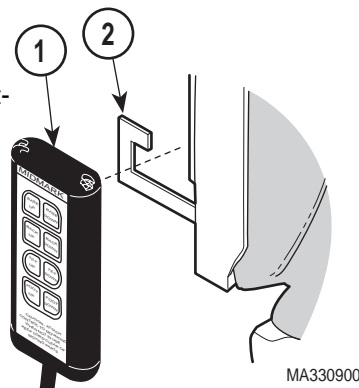

Controls &
Indicators

Operation

Foot Control (optional)



CAUTION

Keep foreign objects away from the foot control. Also, be sure the foot control is not positioned below the foot section or head-lock assembly of the table so that the pedals and switches of the foot control are not inadvertently activated. Failure to do so could result in frightened patient and / or damage to table.



EQUIPMENT ALERT

The foot control is moisture resistant and runs on low voltage, eliminating foot control shock hazards. However, to avoid temporary or permanent damage to the foot control, avoid immersing the foot control in water / fluids.

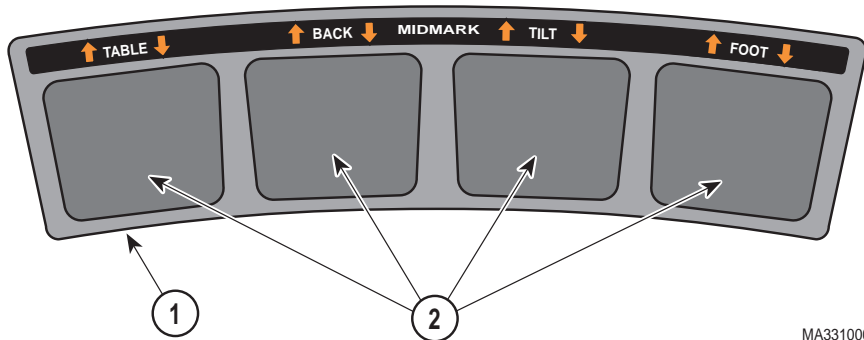

MA331000

Operation

Place the foot control (1) where it will not be in the way of other staff members, but can easily be reached by the operator. With a firm stance, place your foot on the footswitch rocker (2) for the desired function. Tilting your foot to the left activates the function in the UP direction. Tilting your foot to the right activates the function in the DOWN direction. Hold the footswitch rocker down until the desired position is achieved or the function reaches the end of its travel and stops moving. Remove your foot from the foot control when table positioning is completed. A more detailed description of each of the foot control functions is included throughout the remainder of this section.

Back Section Positioning



CAUTION

When positioning the table, keep your toes and feet away from the headrest section of the table. The headrest assembly may collide with the floor, depending on how the headrest section is positioned.



EQUIPMENT ALERT

The Back function will automatically stop moving when either the Up or Down travel limit is reached, but the actuator motor will continue to run. Do not continue to operate a function that has reached its limit; this will cause the motor to overheat and may reduce the life of the actuator motor.

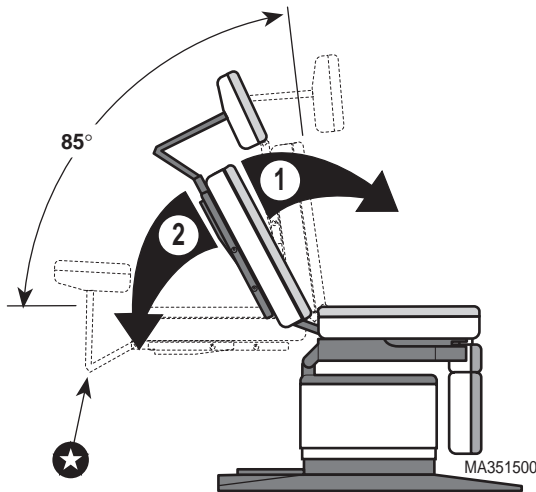
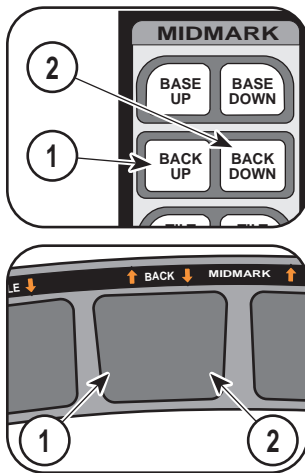

The back section can be positioned at any angle between horizontal and +85°. To adjust the back section from a horizontal position to a chair position, depress and hold the Back Up button (1) until the back section reaches the desired angle or the chair position is achieved. To adjust the back section from a chair position to a horizontal position, depress and hold the Back Down button (2) until the back section reaches the desired angle or the horizontal position is achieved.

Depending on how the headrest is positioned, the headlock arm (★) may collide with the floor or other object when the head end of the table top is being lowered. To correct a collision situation, use the Tilt Down or Table Up functions to raise the headlock arm off the of the floor (or other object it is contacting). Now, further Back Down operation may be continued.

Tilt Function Positioning (Table Top Angle)

 **CAUTION**
When positioning the table, keep your toes and feet away from the lowest section of the table. The headrest assembly may collide with the floor, depending on how the headrest section is positioned.

 **EQUIPMENT ALERT**
The Tilt function will automatically stop moving when either the Up or Down travel limit is reached, but the actuator motor will continue to run. Do not continue to operate a function that has reached its limit; this will cause the motor to overheat and may reduce the life of the actuator motor.

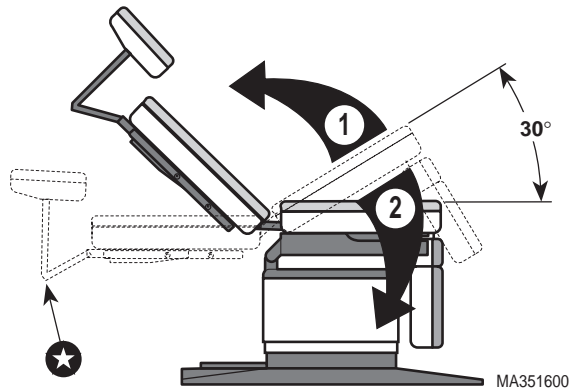
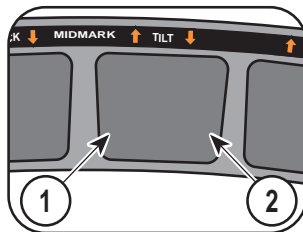
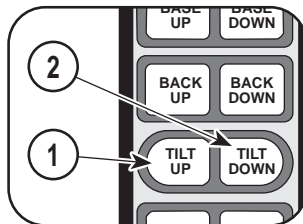

MA351600

Operation

The plane of the table top can be positioned at any angle between horizontal and +30° (foot up). To tilt the head end of the table top downward, depress and hold the Tilt Up button (1) until the table top reaches the desired angle or the maximum downward tilt is achieved. To tilt the head end of the table upward, depress and hold the Tilt Down button (2) until the table top reaches the desired angle or the horizontal position is achieved.

Depending on how the headrest is positioned, the headlock arm (★) may collide with the floor or other object when the head end of the table top is being lowered. To correct a collision situation, use the Back Up or Table Up functions to raise the headlock arm off the floor (or other object it is contacting). Now, further Tilt Up operation may be continued.

Table Function Positioning (Table Height)



CAUTION

When positioning the table, keep your toes and feet away from the headrest section of the table. The headrest assembly may collide with the floor, depending on how the headrest section is positioned.

NOTE

The Table function will automatically stop moving when either the Up or Down travel limit is reached. Even if its button is depressed, the actuator will not continue to run (as the other actuator motors will). Sensors prevent the actuator motor from running when it has reached its Up or Down travel limit, thus preventing excessive wear of the actuator due to full weight of table and patient.

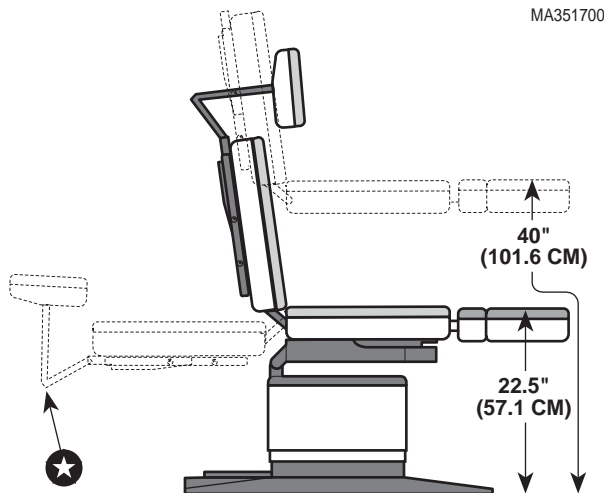
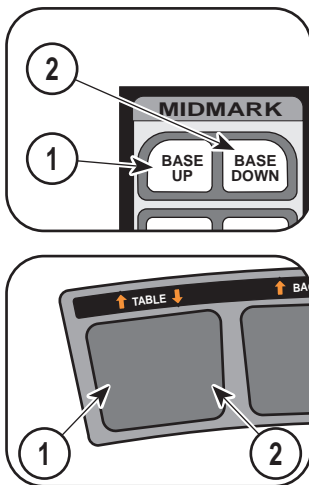

MA351700

Operation

The table top can be positioned at any height between 22.5 - 40 in. (57.1 - 101.6 cm). To raise the table top upward, depress and hold the Table Up button (1) until the table top reaches the desired height or the maximum height is achieved. To lower the table top downward, depress and hold the Table Down button (2) until the table top reaches the desired height or the minimum height is achieved.

Depending on how the headrest is positioned, the headlock arm (★) may collide with the floor or other object when the head end of the table top is being lowered. To correct a collision situation, use the Back Up or Tilt Down functions to raise the headlock arm off the floor (or other object it is contacting). Now, further Table Down operation may be continued.

Foot Section Positioning



EQUIPMENT ALERT

The Foot function will automatically stop moving when either the Up or Down travel limit is reached, but the actuator motor will continue to run. Do not continue to operate a function that has reached its limit; this will cause the motor to overheat and may reduce the life of the actuator motor.

NOTE

A safety switch (★) prevents operation of the Foot Up function when the irrigation pan slide (★) is extended; this prevents the foot section from colliding with the irrigation pan slide. If the Foot Up function is not operable, but the Foot Down function is, check to ensure that the irrigation pan slide is in its fully stowed position. A light clicking sound will be heard just before the irrigation pan slide reaches its fully stowed position.

Operation

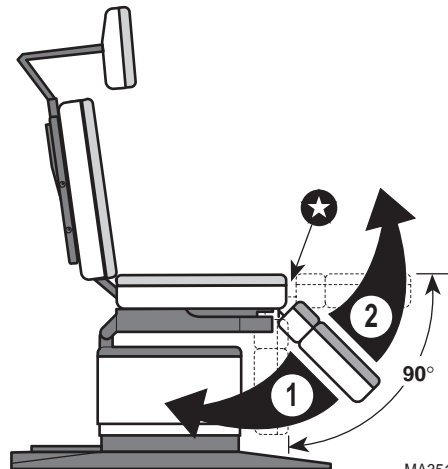
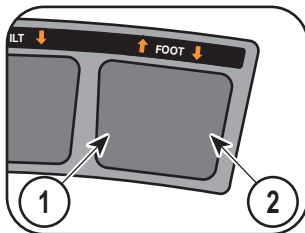
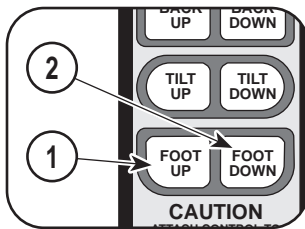

The foot section can be positioned at any angle between horizontal and -90°. To adjust the foot section from a horizontal position to a vertical position, depress and hold the Foot Down button (1) until the foot section reaches the desired angle or the vertical position is achieved. To adjust the foot section from a vertical position to a horizontal position, depress and hold the Foot Up button (2) until the foot section reaches the desired angle or the horizontal position is achieved.

Multiple Function Positioning

Multiple functions can be operated at the same time to speed positioning. However, there are two groups of functions and only the functions within the same group can be operated at the same time. The two groupings for multiple functions are:

- Table Up, Back Down, Tilt Up, and / or Foot Up
- Table Down, Back Up, Tilt Down, and / or Foot Down

Procto Knee Rest Positioning

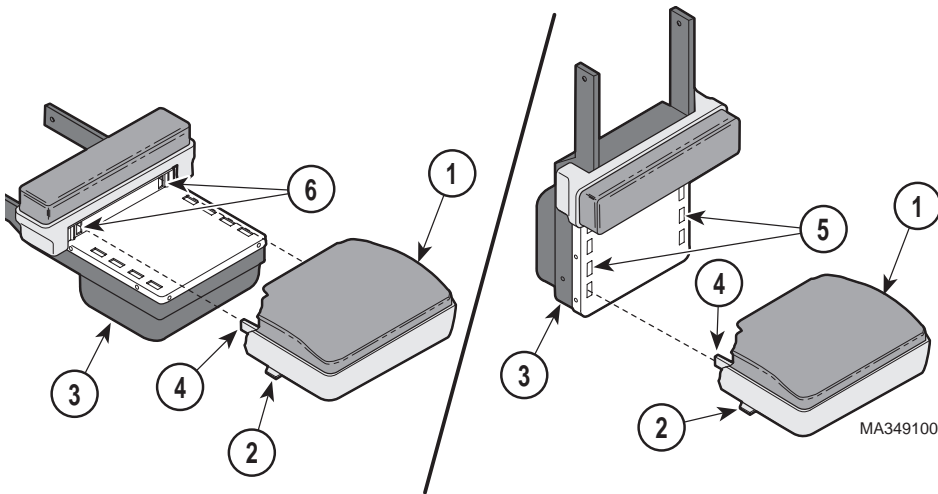

There are four height positions in which the procto knee rest (1) can be set for.

To remove the procto knee rest, lift release levers (2) on each side of procto knee rest (1) and pull procto knee rest straight away from table.



CAUTION

Make sure the procto knee rest is securely latched in place before using with patient. Failure to do so could result in serious personal injury.

To position the procto knee rest, depress the Foot Down button and lower the foot section (3) down all the way. Then, insert the metal guides (4) of procto knee rest (1) into one of the four procto knee rest positions (5) provided until the mechanical locking hooks can be seen or heard to engage. Pull on the procto knee rest (1) to ensure that it is securely latched in place.

To return the procto knee rest to its stowed position, lift release levers (2) on each side of procto knee rest (1) and pull knee rest out of procto knee rest position (5). Then, insert the metal guides (4) of procto knee rest (1) into foot rest slots (6). Pull on the procto knee rest to ensure that it is securely latched in place.

Stirrups

To erect the stirrup, grasp end of stirrup and pull stirrup straight out of table to full extension. Unfold stirrup upward to an erect position.

NOTE

If you are applying any downward pressure on the end of the stirrup when sliding it in or out, it may be very difficult to move. This is normal and is part of the stirrup extension locking mechanism. For ease of movement, lift up slightly while sliding the stirrup in or out.

To adjust the stirrup extension length, hold the end of the stirrup and slide in or out until the desired extension is achieved.



WARNING

Failure to engage the lateral locking mechanism could allow patient to lose balance resulting in personal injury to patient.

To adjust the lateral position of a stirrup, lift end of stirrup and then rotate stirrup to the right or left into one of the three possible lateral positions. The stirrup will click into each position as it is rotated. When the desired position is attained, lower stirrup to engage the lateral locking mechanism. Check that lateral locking mechanism is engaged by attempting to rotate stirrup assembly without lifting on stirrup end.

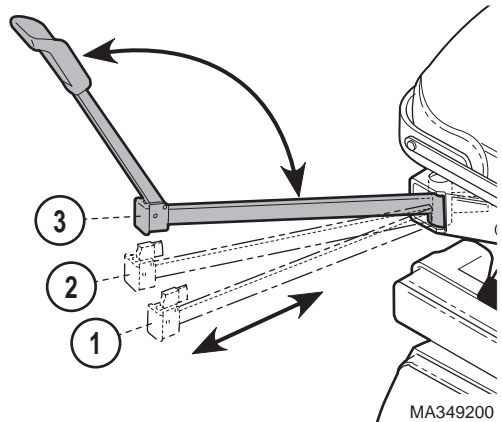

To return stirrup to storage, grasp end of stirrup and pull stirrup straight out to full extension. Fold stirrup down against bar, rotate stirrup to lateral position 2, and then slide stirrup back into stowed position.

Irrigation Pan

NOTE

A safety switch prevents operation of the Foot Up function when the irrigation pan slide (2) is extended; this prevents the foot section from colliding with the irrigation pan slide. If the Foot Up function is not operable, but the Foot Down function is, check to ensure that the irrigation pan slide is fully stowed. A light clicking sound will be heard just before the irrigation pan slide reaches its fully stowed position.

To expose the irrigation pan (1) for use, grasp the irrigation pan slide handle (2) and pull until pan slide is fully extended.

To clean the irrigation pan (1); the irrigation pan (1) can easily be removed for cleaning when the irrigation pan slide (2) is fully extended. To replace the irrigation pan (1), align pan and then press pan firmly into pan slide (2).

To stow the irrigation pan (1) after use, push in on irrigation pan slide handle (2) as far as it will go. A light clicking sound just before the irrigation pan slide reaches its fully stowed position indicates that the pan slide (2) is properly stowed.

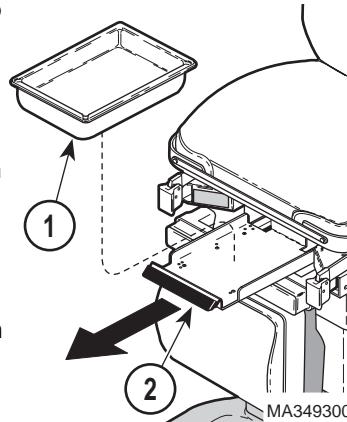

Paper Roll

Storage for two standard 18 in. wide x 3 in. diameter (45.7 x 7.6 cm) paper rolls (1) is provided under the upper portion of the back section.

To change a paper roll, access the paper roll storage area by sliding the paper roll holder (2) toward the top of the back section (it is recommended to have the back section in a horizontal position). Insert the paper roll(s) (1) in the paper roll holder (2), drape the end of the paper roll nearest the top of the back section out of the paper roll holder, and then push the paper roll holder down under the back section. Remove one end of

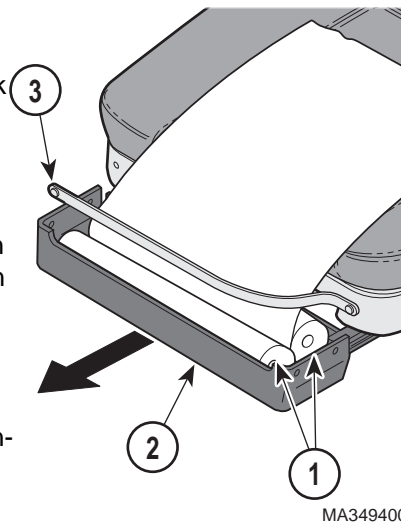

paper tear straps (3) and then pull paper over the upholstery. Replace the paper tear straps (3) to help secure the paper. New paper may now be pulled out quickly and easily for each patient.

Headrest Removal / Installation

The headrest can be removed or exchanged with another headrest to facilitate some procedures.

To remove a headrest, pull the three retaining latches (1) outward and then pull up on the headrest (2) to release the headrest from the headrest mount (3).

To install a headrest, align the three headrest studs (4) with headrest mount (3) and then push the headrest firmly onto the headrest mount. Secure the headrest (2) by pushing the three retaining latches (1) inward until they are latched.

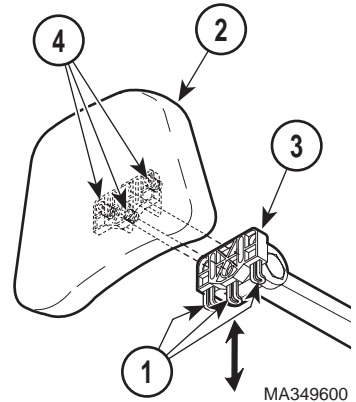

Headrest Positioning



WARNING

Make sure headrest is securely locked into position before use. Failure to have the upper and lower handles correctly locked could result in headrest falling during a procedure. This could cause serious personal injury.

Upper handle (1) and lower handle (2) are used to control the positioning of the headrest by locking and unlocking three rotational joints (3, 4, and 5) of the headlock assembly.

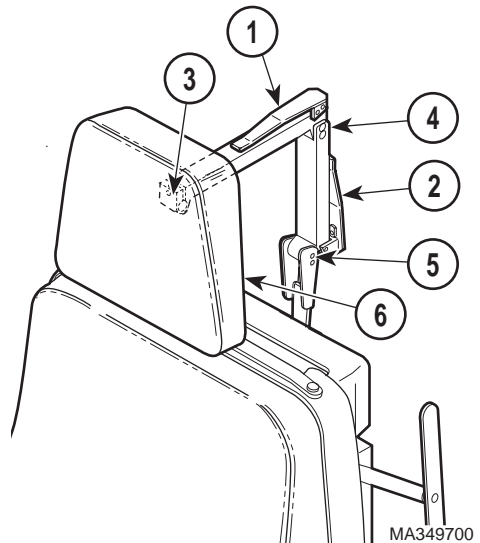

To position the headrest (6), grasp upper handle (1) and pull it outward. This releases tension at joints (3 and 4). Position upper arm and headrest as desired; then push inward on upper handle (1) to lock joints (3 and 4) in place. Grasp the lower handle (2) and pull it out-

ward. This releases tension at joint (5). Position lower arm as desired; then push inward on lower handle (2) to lock joint (5) in place. Repeat these steps until the headrest (6) is positioned as desired. Make sure upper and lower handles (1 and 2) are locked correctly (a handle is locked correctly when it is pushed past center and the force of the clamping action pulls the handle into locked position and holds it there).

Accessory Rails

A 3/8 in. wide (9.5 mm) x 1 in. (25.4 mm) tall accessory rail (1) is located along each side of the back section for mounting of authorized accessories.

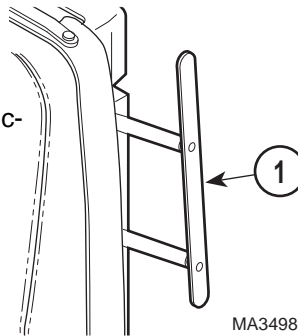

List of Authorized Accessories

Listed below are the accessories which are authorized for use with the table.

<u>Accessory Name</u>	<u>Order Number</u>
• Chair Arm Set Assembly	9A4300X
• Facial Pad	9A5100X
• I.V. Pole	9A7700X
• Vision Block Screen	9A7800X
• Articulating Armboard	9A8100X
• Surgery Armboard	9A8200X
• Instrument Tray Assembly	9A8300X
• Foot Rest Step	9A8500X
• Upholstery Cover Set	9A8700X
• Knee Crutch Assembly	9A14400X
• Side Rail Assembly	9A15700X
• Fixed Armboard Assembly	9A17900X
• Welch Allyn Hanger	9A18200X
• Round Headrest Assembly	9A19800X
• Surgery Headrest Assembly	9A19900X
• Urology Accessory	9A20400X
• Base Rail Assembly	9A20500X
• Knee Crutch Assembly	9A20800X
• Caster Base Assembly	9A21300X
• Restraint Belts	9A21400X
• One Arm Wrist Rest	9A22100X
• Two Arm Wrist Rest	9A22200X
• Seat Rail Assembly	9A22700X
• Siderail Socket Accessory	9A22900X
• Siderail Adapter Accessory	9A23000X
• Foot Control Assembly	9A20300X

Operation

OPERATOR MAINTENANCE

Preventive Maintenance

Little routine maintenance is required other than periodic inspection of the electrical cord to ensure it is free of cuts or damage, periodic inspection of the mechanical functions to ensure satisfactory operation, and periodic check of fasteners to ensure they are present and tightened securely.

Oil moving parts (such as back hinge, irrigation pan slides, and the stirrup index button) with a light machine oil to assure quiet, smooth, and dependable operation. Stirrup bars and accessory rails can be lubricated using common household furniture wax.

Have your authorized dealer inspect your table every six months.

Headlock Assembly Adjustment

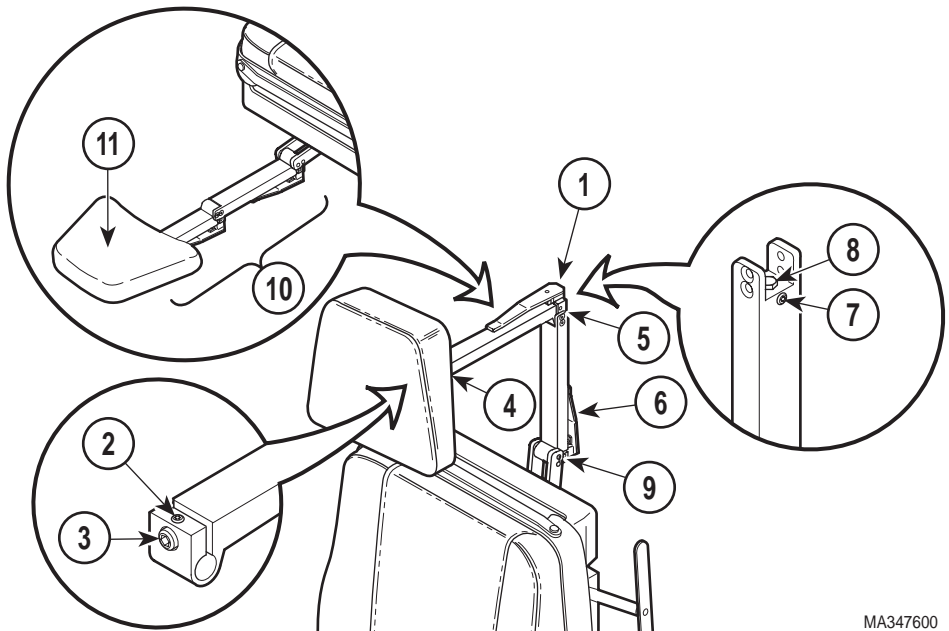

MA347600

The wrenches necessary to adjust the headlock assembly have been provided. These wrenches are in a bag which has been attached to the headlock assembly of the table. Remove this bag of wrenches before using the table and store these tools with the Installation & Operation Manual.



WARNING

Failure to adjust the headlock assembly to specifications could result in a failure during a procedure. This could cause severe personal injury to a patient or the need to terminate the procedure.

NOTE

The maximum force required to unclamp a locking handle should be 17 lbs. (7.7 kgs) and the maximum force required to clamp a locking handle should be 35 lbs. (15.8 kgs).

1. Unlock upper lock handle (1); then loosen setscrew (2).
2. Tighten adjusting screw (3) slightly; then lock upper lock handle (1). Repeat this step until joints (4 and 5) have the strongest possible holding power, but operation of upper lock handle (1) is not too difficult. Then, tighten setscrew (2).
3. Unlock lower lock handle (6); then loosen setscrew (7).
4. Tighten adjusting screw (8) slightly; then lock lower lock handle (6). Repeat this step until joint (9) has the strongest possible holding power, but operation of lower lock handle is not too difficult. Then, tighten setscrew (7).
5. Lower Back Down function all the way down.
6. Position the headlock assembly (10) in fully extended position. Then, place a 45 lb. (20.4 kg) weight on the center of headrest (11).
7. Observe. The headlock assembly (10) should support the test weight without drifting downward. If not, repeat entire adjustment procedure. If headlock assembly (10) does not meet test standards, do not use the headlock assembly.

Headlock Handle Stops Adjustment

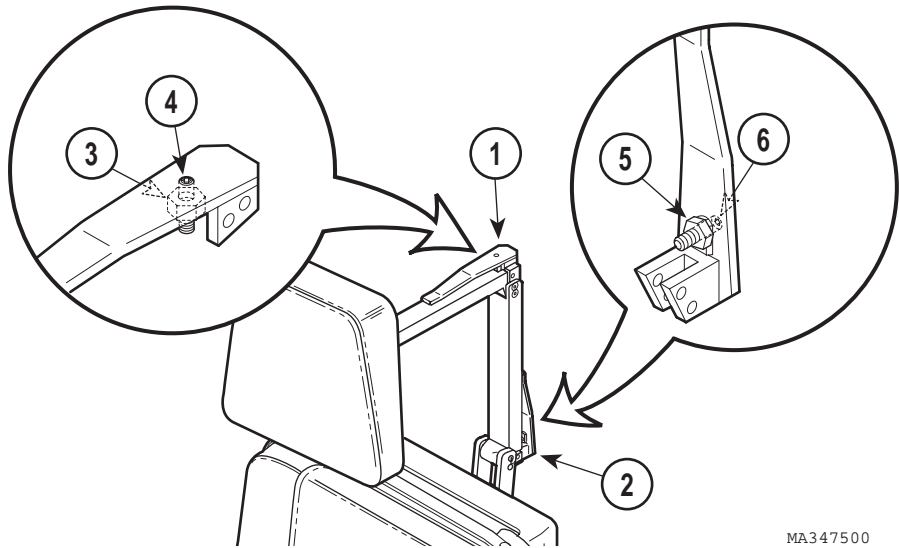

MA347500

If either the upper lock handle (1) or the lower lock handle (2) fails to lock by “going over center” or if there is not enough finger clearance between the headlock assembly and the handle, perform the following adjustment:

1. Loosen nut (3).
2. Push on upper lock handle (1) until it reaches a point where the upper lock handle wants to lock itself by going over center; then allow the upper lock handle to go over center a few degrees. Hold the upper lock handle (1) in this position and adjust stop screw (4) so the upper lock handle will be forced to stop in this position each time it is locked. Then, tighten nut (3).
3. Loosen nut (5).
4. Push on lower lock handle (2) until it reaches a point where the lower lock handle wants to lock itself by going over center; then allow the lower lock handle to go over center a few degrees. Hold the lower lock handle (2) in this position and adjust stop screw (6) so the lower lock handle will be forced to stop in this position each time it is locked. Then, tighten nut (5).

Care of Table



EQUIPMENT ALERT

The upholstery material that covers the top of the table is resistant to most medicinal-types stains, but may be damaged by solvents and dyes. Remove any fluids which are spilled on the upholstery immediately.

Clean the table weekly, wiping the painted metal and plastic surfaces with a clean, soft cloth. If desired, mild cleaners may be used. Periodic applications of common furniture wax will ease cleaning and help to maintain the finished luster of the table.

Moving parts such as hinge and pivot pins, stirrup index button, pan slides, and other moving parts should be oiled occasionally with a light machine or spray oil to maintain quiet, smooth, dependable operation. Stirrup bars and accessory rails can be lubricated using common household furniture wax.

CALLING FOR SERVICE

If you are having a problem or have a question, refer to the inside front cover of this manual and call your dealer. Make sure that you have the information that is highlighted on the inside front cover of this manual available. If you can't resolve your question or problem with your dealer, call the following number:

1-800-Midmark (1-800-643-6275)

8:00 a.m. until 5:00 p.m. (Eastern Standard time in the U.S.)

Monday thru Friday, except for standard U.S. holidays.

**Operator
Maintenance**

**Calling For
Service**

SPECIFICATIONS

Patient Weight (Maximum)	325 lbs (147.4 kgs)
Weight of Table	515 lbs (233.6 kgs)
Back Section Range	0° (horizontal) to +85°
Table Top Height Range	22.5 in. to 40 in. (57.1 cm to 101.6 cm)
Foot Section Range	0° (horizontal) to -90°
Table Top Tilt Range	0° (horizontal) to +30° (foot up)
Dimensions:	
Upholstered top	27.0 in. wide x 69.25 in. long (68.6 cm x 175.9 cm)
With Headrest Extended	82.75 in. (210.2 cm)
Electrical Requirements	115 VAC nominal (126 VAC maximum - 110 VAC minimum), 60 HZ, 12 amps maximum
Paper Rolls	Can accept two standard paper rolls of 18 in. x 3.0 in. (45.7 cm x 7.6 cm)
Power Cord	extends 70 in. (Minimum) from table. 12 AWG / 3 conductor, SJT grey jacketed junior hard service with hospital grade grounding type plug.
Certifications:	U.L Listed Medical Equipment CSA Standard C22.2 #125 ISO-9001 Certified

LIMITED WARRANTY

SCOPE OF WARRANTY

Midmark Corporation (“Midmark”) warrants to the original purchaser its new Alternate Care products and components (except for components not warranted under “Exclusions”) manufactured by Midmark to be free from defects in material and workmanship under normal use and service. Midmark’s obligation under this warranty is limited to the repair or replacement, at Midmark’s option, of the parts or the products the defects of which are reported to Midmark within the applicable warranty period and which, upon examination by Midmark, prove to be defective.

APPLICABLE WARRANTY PERIOD

The applicable warranty period, measured from the date of delivery to the original user, shall be one (1) year for all warranted products and components.

EXCLUSIONS

This warranty does not cover and Midmark shall not be liable for the following: (1) repairs and replacements because of misuse, abuse, negligence, alteration, accident, freight damage, or tampering; (2) products which are not installed, used, and properly cleaned as required in the Midmark “Installation” and or “Installation / Operation Manual for this applicable product. (3) products considered to be of a consumable nature; (4) accessories or parts not manufactured by Midmark; (5) charges by anyone for adjustments, repairs, replacement parts, installation, or other work performed upon or in connection with such products which is not expressly authorized in writing in advance by Midmark.

EXCLUSIVE REMEDY

Midmark’s only obligation under this warranty is the repair or replacement of defective parts. Midmark shall not be liable for any direct, special, indirect, incidental, exemplary, or consequential damages or delay, including, but not limited to, damages for loss of profits or loss of use.

NO AUTHORIZATION

No person or firm is authorized to create for Midmark any other obligation or liability in connection with the products.

THIS WARRANTY IS MIDMARK’S ONLY WARRANTY AND IS IN LIEU OF ALL OTHER WARRANTIES, EXPRESS OR IMPLIED. MIDMARK MAKES NO IMPLIED WARRANTIES OF ANY KIND INCLUDING ANY WARRANTIES OF MERCHANTABILITY OR FITNESS FOR ANY PARTICULAR PURPOSE. THIS WARRANTY IS LIMITED TO THE REPAIR OR REPLACEMENT OF DEFECTIVE PARTS.

SF-1487 REV. A1

Specifications

Limited
Warranty

MIDMARK[®]

Midmark Corporation, Versailles, Ohio 45380 U.S.A.
937-526-3662 FAX: 937-526-5542

© Midmark Corporation - 1997

003-0833-00 Rev. B (9/98)